

How to match right bands to right manifold to right cylinders? Or the other way around!

There are different ways in different "cultures" how to specify all information.

We hope this will help You to find the right parts for Your assembly, regardless of how You measure.



Cylinder size in Litres.

Size	Diamet.	Circum.	CC in mm.	Part No:	Code
2x6L	141	443	150	AB150	G
2x6L	141	443	177	AB177	J
2x6L	141	443	184	AB184-67	F
2x7L	141	443	150	AB150	G
2x7L	141	443	184	AB184-67	F
2x10L	171	540	184	AB184	A
2x10L	171	540	190	AB190	C
2x10L	178	559	190	AB191	B
2x12L	171	540	184	AB184	A
2x12L	171	540	190	AB190	C
2x12L	178	559	190	AB191	B
2x15L	203	640	214	AB214	D
2x15L	203	640	220	AB220	E
2x18L	203	640	214	AB214	D
2x18L	203	640	220	AB220	E



Just band-kits

ID letter on welded band washer

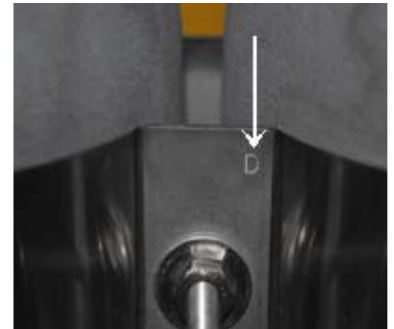

Just band-kits

Just band-kits



By cylinder size in cuf.

Size steel	Size Alu.	Diameter	Circum.	C.C inch	Part No	Code
80/100/120	80/63cuf	7,25"	22,9"	8,5"	AB21480	K
95/104-140	92/100	8"	25,4"	8,5"	AB214104	H

Easier way of measuring

Centre to Centre: e.g. 190mm / 7,5"

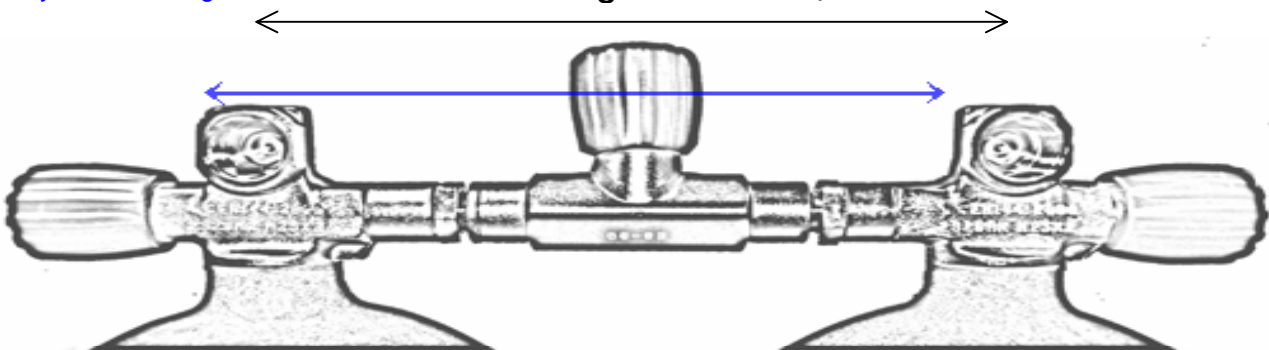

For a missing size or any other information, please contact us.

sales@agir-brokk.com

tel +46 8 716 50 90

